

b) The circular disk shown in figure is subjected to uniformly distributed tangential forces of intensity 300 N/mm. Calculate the moment of these forces about any point O in the plane of the disk.

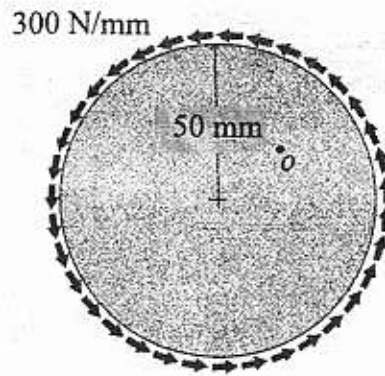

Q3/ a) The force system shown in figure consists of the couple C and four forces. If the resultant of this system is a 25 N.m counterclockwise couple, determine P, Q, and C.

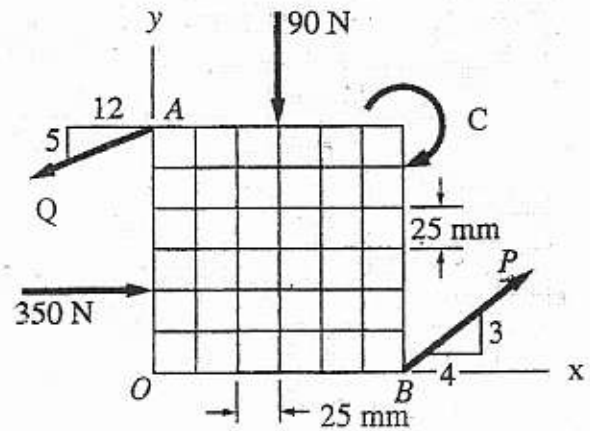

b) Determine the X coordinate of the centroid of the shaded area shown in figure.

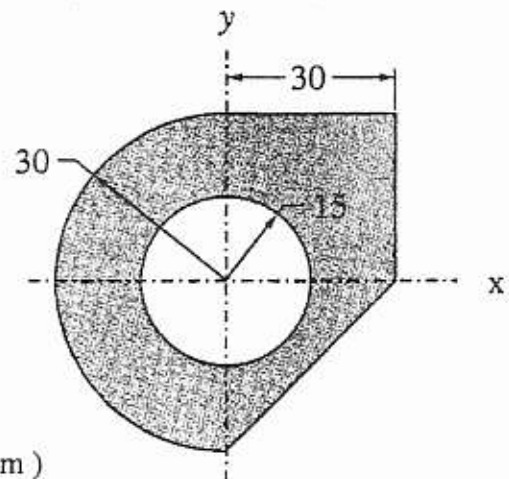

(Dimensions in cm)

Q4/ Blocks A and B weigh 1 kN and 5 kN respectively and are connected by a continuous rope passing over a smooth pulley. In order to prevent the system from moving, a uniformly varying load is applied to member CD as shown in figure. The coefficient of friction at all contact surfaces is 0.2. Determine the minimum value of (w) which prevents motion.

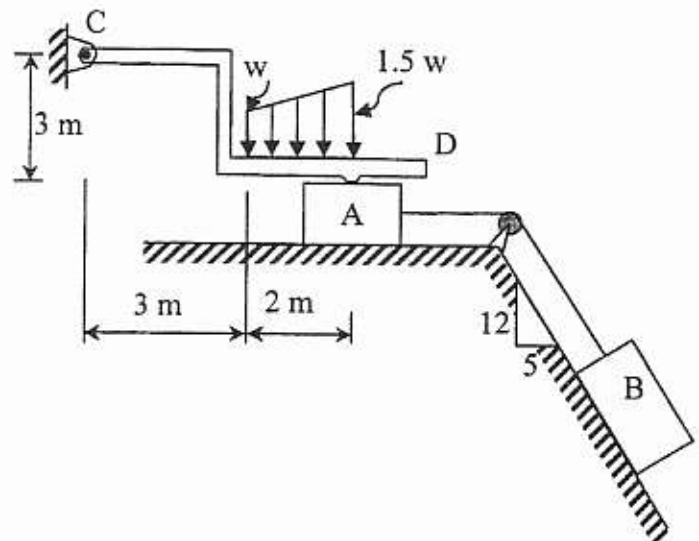

Q5/ a) Determine the product of inertia with respect to axes through the origin.

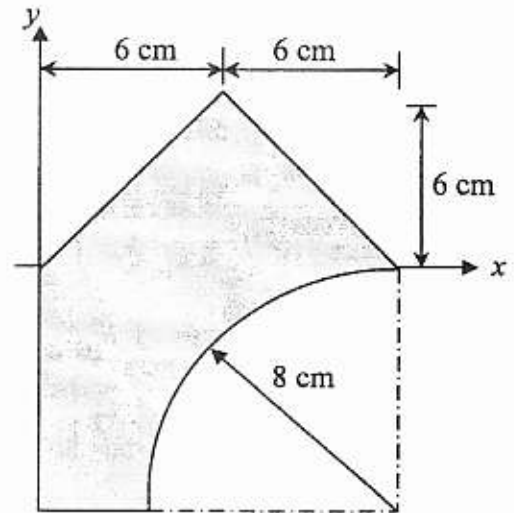

b) Draw free-body diagrams of bars ABC and DEBF and of pulley C of the structural mechanism shown in figure.

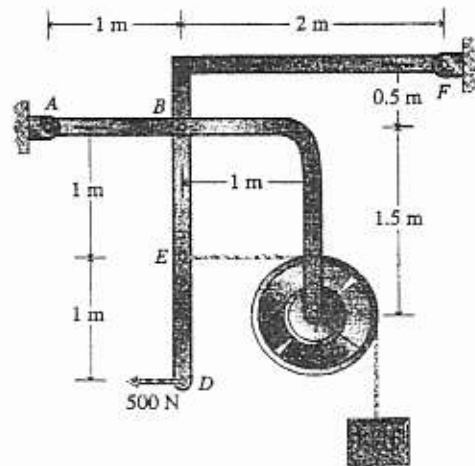

Q6/ a) A particle moves along a horizontal straight line, it has an initial velocity of 6m/sec to the right and a constant acceleration which brings the particle to rest after 3 seconds, then the particle moves with this constant acceleration for another 2 seconds, after which it travels at a constant velocity until its position is 15m to the left of the starting point. Determine the total time of travel.

b) Determine the force in member BD of the truss shown in figure.

