



University Of Technology  
Building and Construction Eng. Dept.  
Final Exam – Second Attempt – 2010/2011



Subject : Strength of Materials.  
Class : Second Year.

Date: 29/ 05/ 2011  
Time : 3 Hours

**Note:** Answer **FOUR** questions only.

Q1: A wooden box beam is to be constructed by nailing four pieces in one of the two ways shown in Fig.(Q1). The allowable bending and shear stresses in the wood are 6 MPa and 2 MPa respectively. The maximum force that the nails can support is 500 N. Determine the maximum value of load  $P$ , the spacing of the nails, and the preferred nailing method.

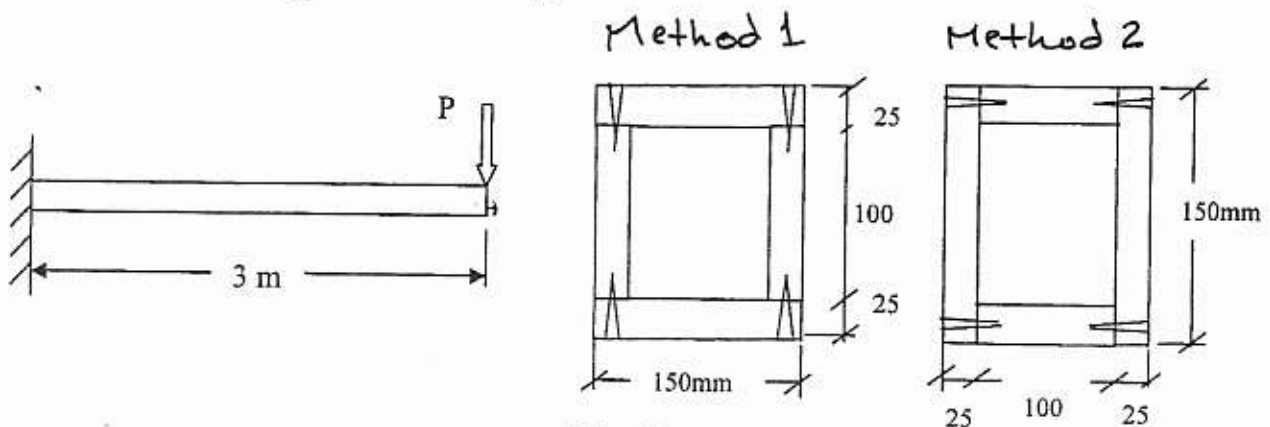

Fig.(Q1)

Q2: A simply supported beam of 4m span carries loads as shown in Fig.(Q2).

At a section 1.5m from left support find either (a) or (b):

- the bending and shearing stresses at the neutral axis and the top edge of section, also find the principal stresses with their planes at these points.
- the maximum magnitude of the normal and shearing stresses, and plot the normal and shear stress distribution acting over the section.

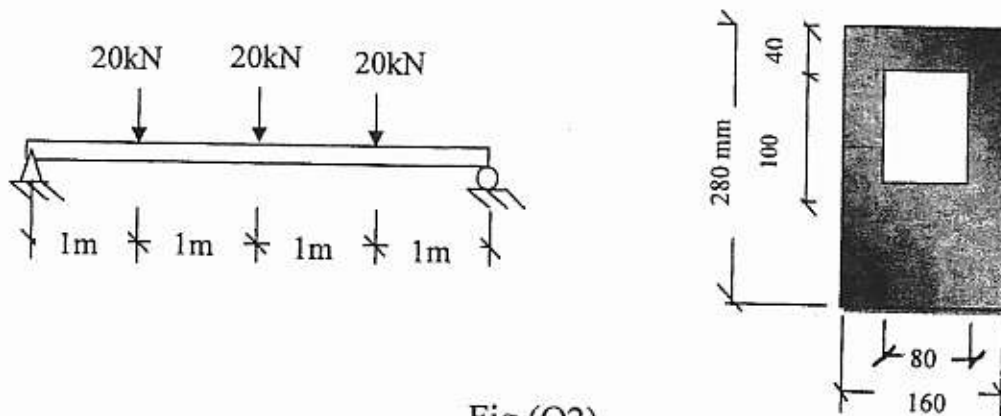

Fig.(Q2)

Q3: A steel shaft and aluminum tube are connected to a fixed support and a rigid disk as shown in Fig.(Q3). A torque  $T=(5 \text{ kN.m})$  is applied to the disk. Determine the thickness of the the aluminum tube( $t$ )if the allowable shear stress are  $120 \text{ MPa}$  in steel and  $76 \text{ MPa}$  in aluminum and the angle of rotation of the disk is limited to  $2^\circ$ . For steel  $G=83\text{GPa}$ ,and for aluminum  $G=28\text{MPa}$ .

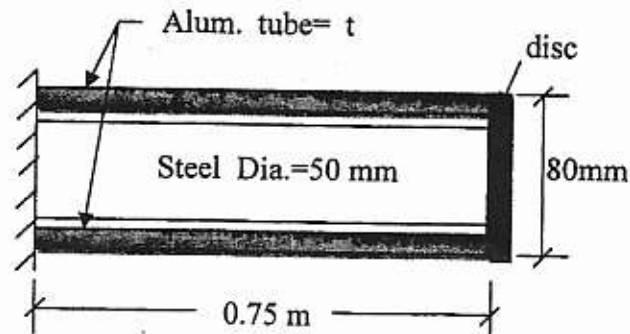

Fig.(Q3)

Q4: Determine the slope at point A and the maximum deflection of the beam shown in Fig.(Q4), using the Moment- area method.  $EI$  is constant.

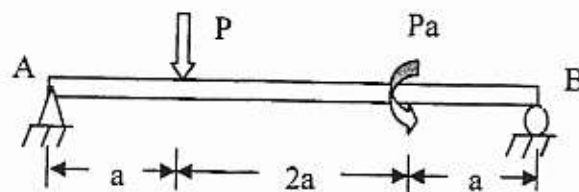

Fig.(Q4)

Q5: Three steel bars A, B, and C ( $E=200 \text{ GPa}$ ) have lengths  $L_A= 4\text{m}$ ,  $L_B= 3\text{m}$ , and  $L_C= 2\text{m}$  as shown in Fig.(Q5). All bars have the same cross-sectional area of  $500\text{mm}^2$ . Determine (1) the elongation in bar B;  
(2) the normal stress in bar C.

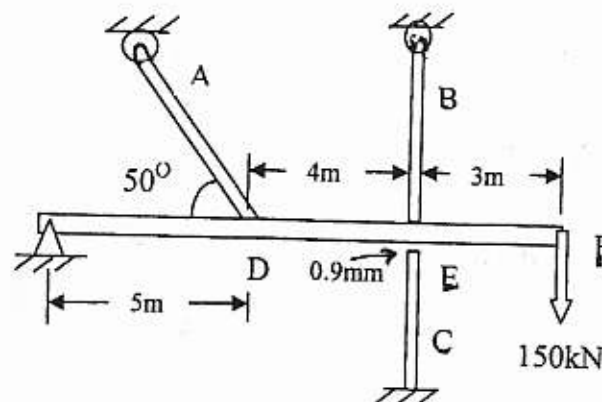

Fig.(Q5)